

ITEM	DESCRIPTION	PART NO.	QUAN.
23	GEAR	260D10-W	1
24	L.S. SHAFT	260D12	1
28	BRG.		2
29	OIL SEAL		2
34	2 ND SHAFT PINION	260D 20	1
35	GEAR	260D30W	1
40	BRG.		2
46	3 RD SHAFT PINION	B-6744	1
47	GEAR	B-6745	1
50	BRG.		2
55	4 TH SHAFT PINION	X-13192-A	1
60	BEVEL GEAR	120-TB-503	1
62	BRG.		2
64	OIL SEAL		1
68	H.S. SHAFT	120-TB-603	1
73	BRG.		2
74	OIL SEAL		1
76	BEVEL PINION	120-TB-703	1

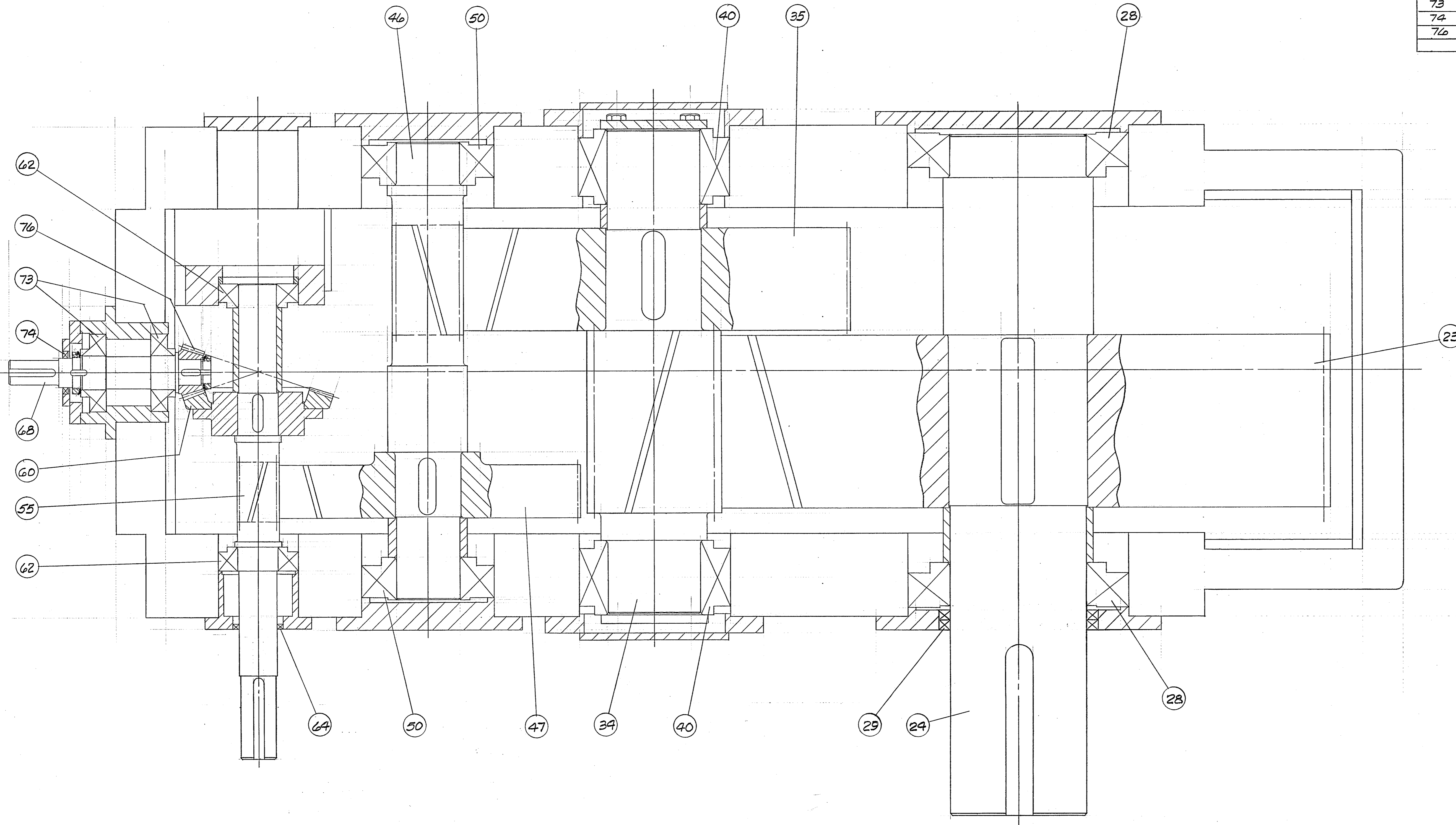

NOTE: ASSEMBLY NO. 2 SHOWN

FINISH SYMBOLS	NO.	REVISION	BY	DATE
32/ POLISH				
62/ GRIND				
82/ FINE MACH.				
122/ SEM-FINE				
250/ MEDIUM				
500/ ROUGH				
MATERIAL	SCALE	REF. DWG.		
DATE	DRAWN	CHECKED	DWG. NO.	REV.
8-29-79	V.T.	V.T.	Y-3821	
	DATE	DATE		
	6-8-79			